



Beverage Systems

Item # _____

Project _____

Date _____



Model # D15 Single Bowl Premix Dispensers

Features

- Famous two-piece, stainless steel, dripless pouring valve is sanitary and easy to use and maintain.
- Better design and more stainless steel allow easier cleaning and less maintenance.
- Superior engineering allows full beverage cooling right down to the last drink.
- Large, 5 gallon bowl, with easy to read measuring marks.
- Super-strong, virtually unbreakable polycarbonate bowl and cover give lasting durability.
- Unique evaporator and high efficiency pump cools faster and more efficiently for faster start-ups.
- Choice of Regular (-4) or optional Stainless Steel (-3) side panels and drain tray.
- Down-to-earth design engineering makes routine servicing easier and simpler.
- Second-to-none quality with "field condition" testing.
- Optional whipper for frothed drinks.
- Agitators are included with each unit for fresh juices, coffees or teas.
- World-wide sales and service assure customer satisfaction.



GRINDMASTER™
CORPORATION



Grindmaster® Coffee Grinders and Brewers • PrecisionBrew™ Brewing Systems • Espresso® Espresso Machines
Crathco® Hot Beverage Dispensers • Crathco® Cold and Frozen Beverage Dispensers • AMW Coffee and Tea Systems
Tel (502) 425-4776 • Fax (502) 425-4664 • 1-800-695-4500 (USA & Canada only)

P.O. Box 35020 • Louisville, KY 40232 • USA
www.grindmaster.com • email: info@grindmaster.com

Crathco® Model # D15 Single Bowl Premix Dispensers

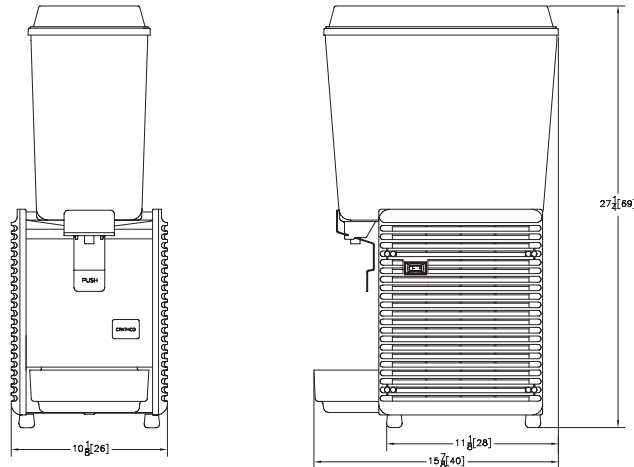

Specifications	D15	D155	D156
# Bowls	1	1	1
Bowl Capacity	5 gallons (18.9L)	5 gallons (18.9L)	5 gallons (18.9L)
Refrigeration	1/6 hp	1/6 hp	1/6 hp
Volts / Hz / Amps	115V / 60Hz / 3Amp	230V / 50Hz / 1.5Amp	230V / 60Hz / 1.5Amp
Dimensions (H x W x D)	27 1/4" x 10 1/8" x 15 7/8" (69 cm x 26 cm x 40 cm)	27 1/4" x 10 1/8" x 15 7/8" (69 cm x 26 cm x 40 cm)	27 1/4" x 10 1/8" x 15 7/8" (69 cm x 26 cm x 40 cm)
Dimensions w/ Whipper (H x W x D)	29 3/4" x 10 1/8" x 15 7/8" (76 cm x 26 cm x 40 cm)	29 3/4" x 10 1/8" x 15 7/8" (76 cm x 26 cm x 40 cm)	29 3/4" x 10 1/8" x 15 7/8" (76 cm x 26 cm x 40 cm)
Ship Weight	46 lbs (20.4 kg)	46 lbs (20.4 kg)	46 lbs (20.4 kg)
Ship Weight w/ Whipper	50 lbs (22.7 kg)	50 lbs (22.7 kg)	50 lbs (22.7 kg)
Cup Height	8 1/4" (20.3 cm)	8 1/4" (20.3 cm)	8 1/4" (20.3 cm)
Cup Height w/ Whipper	5 1/2" (12.7 cm)	5 1/2" (12.7 cm)	5 1/2" (12.7 cm)
Listings	UL, NSF, CUL	NSF, CE	NSF, CE

Specifications are subject to improvement or change without notice.

Standard Options*	
Side panels & drip tray	-3 Stainless steel material (additional charge), -4 off-white high impact plastic (standard - no additional charge)
Valve cap (part# 2039)	Improves sealing of valve when using pulpy products
Valve locking box (part# 2502) (use w/ standard handle)	Secures the valve from dispensing during off-hours - not to be used with non-contact handle
Liquid Auto Fill (part# 90295)	Ensures proper product and mixing consistency, maintains optimum product level in bowls, eliminates need for frequent manual mixing
Shipboard kit (part# 5925)	Makes unit safer for installation aboard marine vessel; only available for use with agitator
Milk Fat Impellers	Use with milk-based products, and/or products with heavy pulp
Condensation Control	Direct and conceal condensation in high humidity or outdoor locations

Custom Options* (available with minimum purchase quantity)	
Frosted Bowls 5 gal. (18.9L)	Frosted surface simulates condensation while helping hide product residue and offering added UV protection.
Frosted Lid	Lid with frosted surface for use with 5 gallon (18.9L) frosted bowls
Whippers (must be ordered when ordering machine), add W before model number	Great for iced cappuccinos and iced coffee. Whips beverage upon dispensing to create a frothy top on drink.

* Additional cost applies



GRINDMASTER™
CORPORATION



Tel (502) 425-4776 • Fax (502) 425-4664 • 1-800-695-4500 (USA & Canada only)

P.O. Box 35020 • Louisville, KY 40232 • USA

www.grindmaster.com • email: info@grindmaster.com