

Item # _____

Project _____

Date _____

Crathco® Model 3341 Remote Condensing Beverage Freezer



MODEL 3341

- Works with remote condensing units up to 2 1/2 hp per freezing cylinder
- Ideal for locations such as theme restaurants, amusement parks, night clubs, casino bars, carnivals and special events
- Versatile...serve frozen cocktails, frozen cappuccino/granita latté, granita, frozen fruit juices, frozen lemonade or slush
- Patented Flavorlight™ illuminates the frozen product while your choice of eye catching back-lit signs draw customers and increase sales
- Compact...More than double the output capacity of visual freezers, on 13" (33 cm) wide counter space
- "Mix Low" light indicates when mix is low in storage hopper
- Reliable mechanical consistency control dispenses perfect product under all operating conditions
- Oversize drive motors, rugged belt drive and heavy duty components keep this freezer running when you need it most
- Optional front mounted spinner blends in an unlimited variety of custom flavors



GRINDMASTER™
CORPORATION

Crathco® Model 3341

Remote Condensing Beverage Freezer

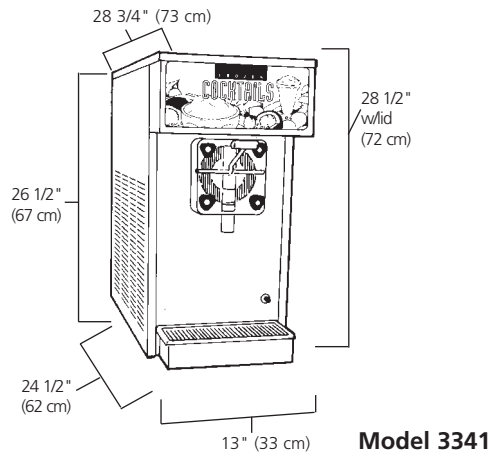

Specifications	Model 3341
Voltage/Watts	115V/60 Hz, 1 Ph, 782W
Amps	6.8A
Capacity	Frozen-1.5 Gal (5.7 liters) storage-5 Gal (19 liters) Total-6.5 Gal (24.7 liters)
Refrig Connections	Units are ready to hookup to customers remote system (5/8" Suction, 3/8 Liquid)
Drive Motor	1/2 hp motor
Dimensions (HxWxD) (Base)	26 1/2" x 13" x 24 1/2" (67cm x 33cm x 62cm)
Dimensions (HxWxD) (electrical box)	26 1/2" x 13" x 28 3/4" (67cm x 33cm x 73cm)
Ship Dimensions (HxWxD)	30" x 17" x 32 1/2" (76cm x 43cm x 83cm)
Weight	110 lbs (49.90 kg)
Ship Weight	140 lbs (63.50 kg)
Optional Accessories	Front mounted spinner 4" (10 cm) legs
Listings	UL, NSF, CUL, CE

Specifications are subject to improvement or change without notice.

Ask about Grindmaster Corporation's line of Coffee Grinders, Coffee Brewers, Coffee Urns, Coffee Shuttles, Coffee Grindermixers, Espresso Grinders, Espresso Brewers, Beverage Dispensers, Granita Machines and Beverage Freezers.

Available with your choice of back-lit header!



GRINDMASTER™
CORPORATION

Grindmaster® Coffee Grinders and Brewers • PrecisionBrew™ Brewing Systems • Espresso® Espresso Machines
Crathco® Hot Beverage Dispensers • Crathco® Cold and Frozen Beverage Dispensers • AMW Coffee and Tea Systems
Tel (502) 425-4776 • Fax (502) 425-4664 • 1-800-695-4500 (USA & Canada only)

P.O. Box 35020 • Louisville, KY 40232 • USA