

Frosty Factory

Model 215-F



- **Double Cylinder** - Serves two flavors
- **(2) 7 Quart Cylinders**
(2) 12 Quart Hoppers
- **High Production** - Up to 155 ten ounce drinks per hour per side
- **Lighted Flavor Sign** - Draws Attention to the frozen product
- **Mobile** - Self contained on locking casters
- **Stand-by-Switch** - Refrigerates mix overnight

Frosty Factory of America

2301 S. Farmerville St., Ruston, LA 71270

www.frostyfactory.com

(318) 255-1162



(800) 544-4071



(318) 255-1170 FAX

Frosty Factory Model 215-F

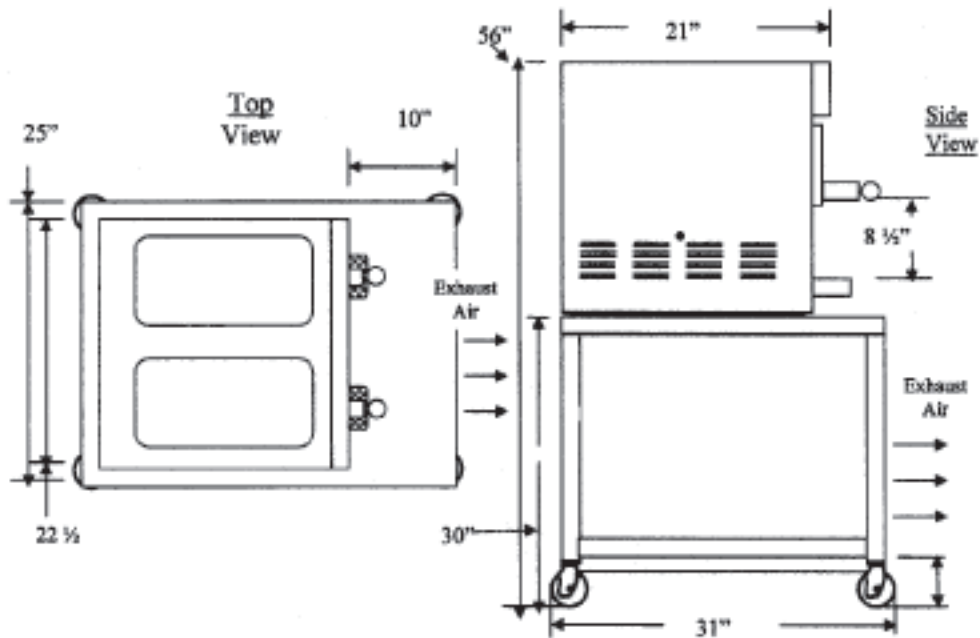

Specifications

- Height: 56 in. -- 142 cm.
- Width: 25 in. -- 63 1/2 cm.
- Depth: 31 in. -- 79 cm.
- Weight: 415 lbs. -- 188 kg.
- Legs: Locking caster 6"
- Shipping Size: 34"W X 29"D X 53"H
86 cm.W X 74 cm.D X 135 cm.H
- Shipping Volume: 30 cu. ft. -- 4/5 cu.M.
- Shipping Weight: 430 lbs. -- 195 kg.
- Voltage: 230
- Hertz: 60 -- Opt. 50
- Phase: 1
- Cooling: Air. Optional water
- Air Clearance: Sides and Rear: 0
Front: 36 in. 91.5 cm
- Water Clearance: Rear: 3 in -- 7 1/2 cm
Sides: None required
- Hopper Capacity: 12 qts. -- 11 1/4 ltr.
- Cylinder Capacity: 7 qts. -- 6 1/2 ltr.
- Amperage Draw: 22 amps
- Circuit Breaker: 30 amp
- Compressor: 3 h.p.
- Refrigerant: R404A



Options: •Autofill •Mixer

Due to continuous research specifications subject to change without notice.

Frosty Factory of America

2301 S. Farmerville St., Ruston, LA 71270

www.frostyfactory.com

(318) 255-1162 ■ (800) 544-4071 ■ (318) 255-1170 FAX